



Commercial Garage Door Operator



1 Year Warranty



Model 8816 Series Two

1 Man Installation Soft Start Extremely Compact and Quiet DC Motor and Controller

Operates doors up to 350 SQ Ft in area / Weight up to 1600 lbs.

Commercial Jackshaft Operator for Vertical Lift, High Lift, Standard Lift and Low Head Room Garage Doors

Standard Features

Motor and controller

- **Easy 1 man mounting over a 1" solid jackshaft or hollow torsion tube, eliminates steel cost for hanging and associated costs like welding, specialty fasteners.**
- **Powerful continuous duty, 1300 Newton, low voltage DC motor.**
- **Dependable Soft Start Controller that eliminates the need for pusher springs on most standard lift and Low Head applications. NEMA 4 single button or three button cover.**
- **Automatic Obstruction Sensing and instant stop and reverse without safety edge and associated coil cord. Controller senses obstruction on any part of the door, not limited to edge contact.**
- **Built in Chain Hoist that automatically engages when override lever is disengaged.**
- **Built in timer to close programming.**
- **Built in service due reminder.**
- **Built in delay close programming.**
- **Built in interlock for Pass-Door**
- **Built in cycle counter**
- **Built in part open programming**
- **Floor level over-ride lever allowing instant manual operation.**
- **Safe operation without constant pressure close. Constant pressure close, available with the flip of a switch.**
- **Pre-wired to accept most photo cells, loop detectors, microwave sensors, treadles, and other accessories.**
- **Built in light control for dock lights turning light on when door is raised and off when door closes or 4 minute timed control for accessory light. 4.5amp Draw. 8 amp draw with dock light.**
- **No thermal overloading.**
- **Easy service. No limits, limit traveler cams, clutches, or contactors to replace.**
- **Minimal Parts to Stock reducing inventory**
- **Eliminates need for 230V or 460V 3 phase power, further reducing electrical construction costs.**
- **Safe operation for use of a slide lock for those situations not requiring the use of radio controls.**
- **Avoids thrown cables.**
- **Versatile application. Operates Vertical lift, High lift, Standard lift, and Low Headroom to include rear mount torsion. Can also be center mounted.**
- **Detects unsafe door operation automatically.**



Commercial Garage Door Operator

Model 8816 Series Two

Accessories

- Battery Back up
- Plug in radio receiver with internal antenna or optional external antenna. Receiver has tunable distance feature to allow repeated use of transmitters on multiple banks of doors. Allows up to 60 Transmitters.
- 2 channel visor grip transmitter
- 4 channel key chain transmitter
- 6 Channel, High Visibility Orange heavy duty transmitter for industrial use
- 1-6 channels, permanently mounted fork lift transmitter that wires to multiple voltage systems, eliminating repeatedly lost or damaged transmitters.
- 871 Interface card that allows the adaptation of non OEM radio controls and additional expansion plugs for stop, close, open functions.
- 872 Expansion base for 10 pin socket connector that allows for use of 871 and 8070 Auto-lock.
- 873 Pull Cord Module.
- 8070 Auto-lock and stop fall device. Electronic solenoid locking system for higher security applications that require the use of radio controls or other outside access accessories.
- 82 TLM Traffic light module. Light control for accessory traffic light for non dock related applications. Provides Interlock for sally port application or other Door closed applications. Also provides additional 10 pin socket connection for auto-lock or 871 interface card application.
- 82DTLM Traffic light module. Light Control for accessory dock access light control. Built in interlock for restricting dock operation or other Door open applications.
- 850 Beeper Module. Enables audible programming of controller and audible annunciation of the service due reminder and operations counter.
- 8042 Motor Cover Kit for standard applications.
- 2414 External mount antenna
- 501256 Rear Mount Torsion Bowden Cable. 12 feet long.
- 501262 Rear Mount Torsion Bowden Cable. 17.75 Feet Long
- 401000 Retro-Reflective Photo Cell. 26' Range.
- 401001 Through Beam Photo Cell. 33' Range.
- ZA0078 Low voltage Motor Cable for with overall height of 16' to 22'.
- (1100-CC) 24V Single Loop Detector with clear view case lid
- (1100-120-CC) 120V Twin Magnetic Loop Detector
- (1100-240-CC) 240V Twin Magnetic Loop Detector

Motor Conversion Parts

8816-A

- (ZA0083) 3"tapped ("A")Driven Pulley
- (600606) AX24 Belt
- (601222) 70MM Drive Pulley

8816-B

- (ZA0084) 4" tapped("B")Driven Pulley
- (600615) AX 25 Belt
- (600222) 79MM Drive Pulley

8816-C

- (ZA0085) 5"tapped ("C")Driven Pulley
- (600614) AX27 Belt
- (600222) 70MM Drive Pulley

88156-D

- (ZA0086) 6"tapped ("D")Driven Pulley
- (600617) AX29 Belt
- (600222) 70MM Drive Pulley

Series II Controller to Series I Controller

- (8800-PNL)

Serviceable Replacement Parts

All 8800 Units Series 1 Units

- (601200) Bearings 2ea
- (8800-II-PNL) Circuit board
- (600810) Replacement Motor
- (501600) Over-ride Lever
- (501250) 6.5' Bowden Cable

8816-A

- (600606) AX 24 Belt

8816-B

- (600615) AX 25 Belt

8816-C

- (600614) AX 27 Belt

8816-D

- (600617) AX 29 Belt



Commercial Garage Door Operator

Dimensional Drawings

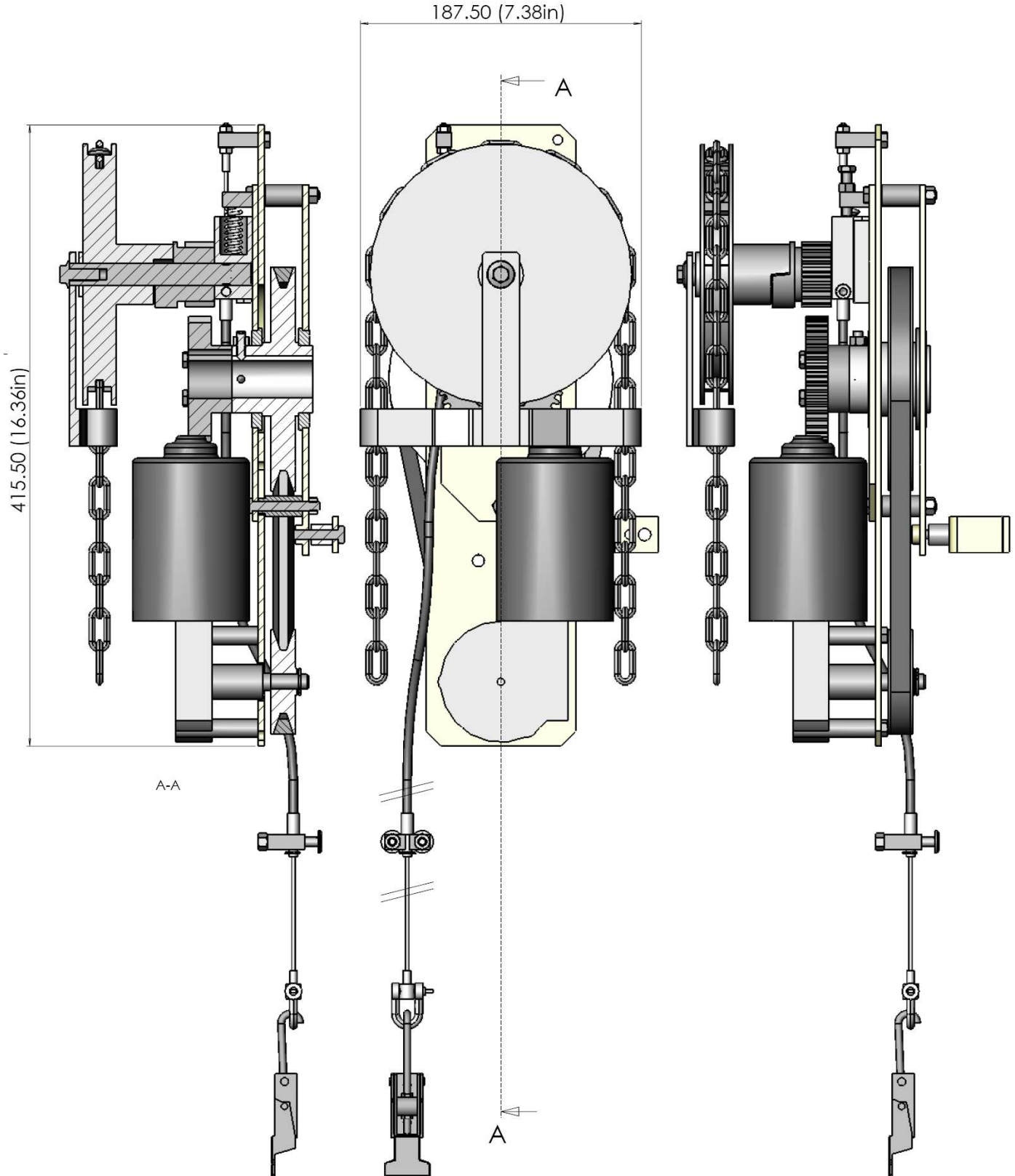



Commercial Garage Door Operator

Dimensional Drawings

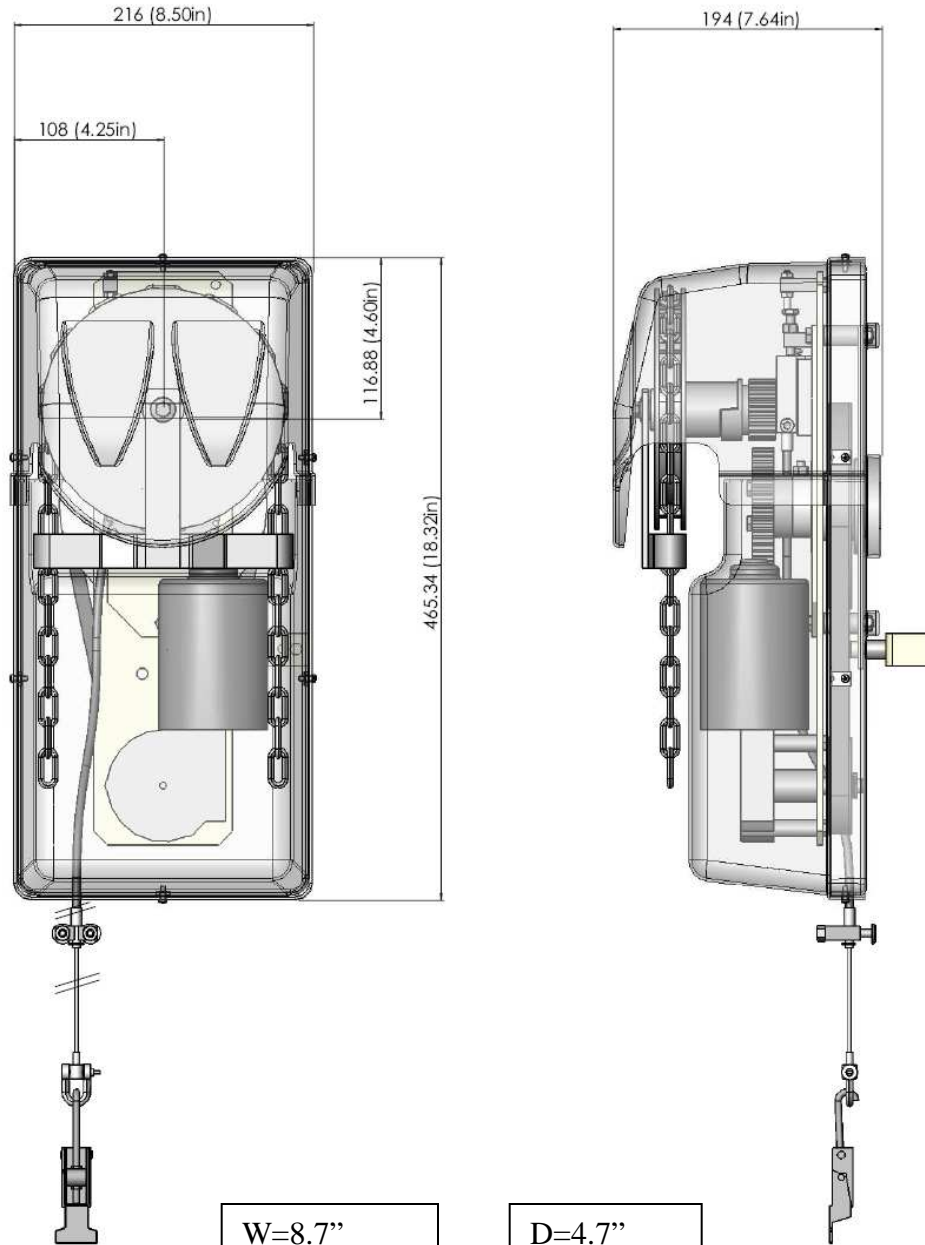

W=8.7"
H=6.8"

D=4.7"
H=6.8"





Commercial Garage Door Operator

ZAP SUPER DRIVE CONTROL SYSTEMS FOR SECTIONAL DOORS GENERAL SPECIFICATION: MODELS 8816

Motor:	8800 SERIES		
Power rating:	1300 Newton's		
RPM:	Fast Speed: 48		
	Slow Speed: 24		
Speed Change Points :	Self-Calibrating		
Max Cycle Count :	Continuous		
Motor Temp/Cycles:	to 37.5 deg C/100 deg F:	24	25
	to 35 deg C/95 deg F :	20	23
	to 30 deg C/85 deg F :	18	21
	to 28 deg C/82 deg F :	16	19
	Operating Temperature Range:	-22 deg F to 212 deg F	
	Overload protection :	Inherent motor current sensing	
	Lubrication:	Permanent	

DRIVE MECHANISM

Drive Means:	High grip Long Life V-Belt.
Reduction means:	Worm Drive Gearbox & V-Belt reduction drive.
	Reduction Drive:
	8816-A: 1.1:1
	8816-B: 1.4:1
	8816-C: 1.8:1
	8816-D: 2.1:1

DOOR SPEED

The door speed will depend upon the type of Cable Drum. A flat form Cable Drum will produce a fairly constant door speed throughout the run time. A Conical drum will cause the door to slow down during the OPEN cycle. The door speed will increase during the CLOSE cycle and will be at the highest speed just before the slow speed change point, which is a few inches above the ground. Typical door speed for the 800 Series 8" - 10"/Sec. If it is desired to run the door slower than normal then an operator with a larger DRIVEN pulley may be fitted. This will also produce more torque and will lift a heavier load. For example a door with 8" diameter cable drums will require a size "C" operator- If a size "D" operator is fitted then the torque will increase by 20% and the speed will reduce by approximately 15%.

Speed reduced to:	8800 series 9" - 12"/Sec
Fitting:	Jackshaft Quick-Fit

DOOR SIZE

Size based upon 4.7Lbs per sq foot.	8800 SERIES
Maximum door size:	350 Sq Feet.
DOOR WEIGHT	8800 SERIES
Maximum door weight	1600Lbs
DOOR HEIGHT	8800 SERIES
Minimum height	9.5Ft
Maximum height:	40Ft

LOGIC TYPE

Solid-State Micro-Controller with built in surge suppression.

TEMPERATURE RANGE

Controller Ambient range -17 deg F to +185 deg F.

The Control unit internal temperature is higher than the outside ambient as the transformer heating warms the internal air. Thus in cold room applications the case internal temperature will be significantly higher than the ambient.

ADJUSTMENTS

Maximum Force/Max Motor Power: Factory preset may be adjusted

Close Sensitivity.

(No limit adjustment is required as it is automatic).

Speed Change Points are Self Calibrating.

ELECTRICAL

Supply:	Single Phase	
Voltage: US:	120V A/C 50/60 Hz	
Wattage:	8800 Motor Controller: 528 watts	
	Lighting output 500 watts	
Current rating:	8800 Motor-Controller:	US: 4.4 Amps
Lighting Output:	US: 4.2 Amps	

LIMIT ADJUSTMENT

None required (Automatic obstruction sensing built-in).

CONVENIENCE/SAFETY

Built in Chain Hoist for manual operation
 Emergency/Quick Release drives disconnect/reconnect.
 Down Safety Reverse.
 impact on any part of the door while closing: Safety Reverse.
 Up Safety Stop.
 Safety Terminals for Photo-Eyes, Magnetic Loop Detectors Etc.
 Auto-Open connections for Loop Detectors, Photo-Eyes or Radar.
 Auto-Close timer: Selectable by panel switch.
 Timer is adjustable from 1 second to 2 minutes.
 Factory preset to 15 seconds.
 Safety circuit break from Photo-Eyes etc. will reset timer.
 Automatic Door Lock option: Plug-in card and Solenoid Lock model 8070.
 Use of standard slide lock allowable when integrated locking mechanism not required

RADIO CONTROLS

Optional Plug in Receiver with Tunable Distance.
 Optional internal antenna or external wall mounting antenna
 Optional 2 Channel Visor Grip Transmitter
 Optional 4 Channel Key Chain Transmitter
 Optional 6 Channel Hand Held Transmitter
 Optional Permanently Mounted Forklift Transmitter. Hardwires to Battery. 1,4,& 6 Channels
 Optional Permanently Mounted Weatherproof Forklift Transmitter. Hardwires to Battery. 1,4,& 6 Channels
 Optional Accessory Radio Interface card model 871 allows interface of other manufacturers externally mounted receivers.
 The operating range of other manufacturers accessory transmitters will depend upon the type and manufacturer.

LIGHTING CONTROL

Operating mode: Switch selectable either:
 A: On a three minute timer from the last door operation.
 B: To switch on when the door opens and off when closed for Loading Bay Dock Light Control

Maximum Wattage: 500 watts

MATERIALS

Jackshaft Drive main components: Steel.
 Pulley: Aluminum.

DIMENSIONS:

CONTROLLER:

8800

H:6.8"

W:8.7"

D:4.7"

JACKSHAFT OPERATOR:

8816

HEIGHT: 16.46"

WIDTH (DRTVE A & B): 7.5"

WIDTH (DRTVE C): 7.5"

WIDTH (DRIVE D): 7.5"

DEPTH (without torque arm): 6.3"

SIDE CLEARANCE:

1.8" (small) offset torque arm:7.7"

2.5" (large) offset torque arm:8.6"

MINIMUM SHAFT

Minimum jackshaft Protrusion:

1.6" (small) offset torque arm:3.75"

2.5" (large) offset torque arm:4.90"