

ZAP[®]™

Sheet Steel Roll-Up door operator

Series II operators for live and dead axle roll-up sheet steel doors

- Quick and Easy Installation
- Soft Start-Fast Open/Close-Soft Stop
- Extremely Compact and Quiet DC Motor and Controller
- Operates doors up to 170 SQ Ft/16 sq Mtrs in area/Weight up to 500 lbs/ 230Kgm
- Easy one man mounting over a 1 5/16" (33.35mm) rolling door shaft, eliminating wall mount and Hood Mount of jackshaft operator on Dead Axle Rolling Sheet Doors. Further eliminates bolting sprockets to the barrel's end. Eliminates welding supports to mount jackshaft operators to walls of steel buildings.
- Powerful continuous duty, 650 Newton, low voltage DC motor.
- Dependable Soft Start Controller that avoids the ballooning of the curtain. NEMA 4 three button controller. Single button controller option.
- Automatic Obstruction Sensing and instant stop and reverse without safety edge and associated coil cord. Controller senses obstruction on any part of the door, not limited to edge contact.
- Built in timer to close programming.
- Built in service due reminder.
- Built in delay close programming.
- Built in cycle counter.

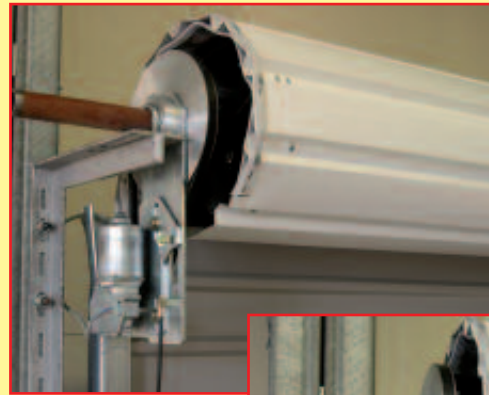

815-SD
STANDARD
operator

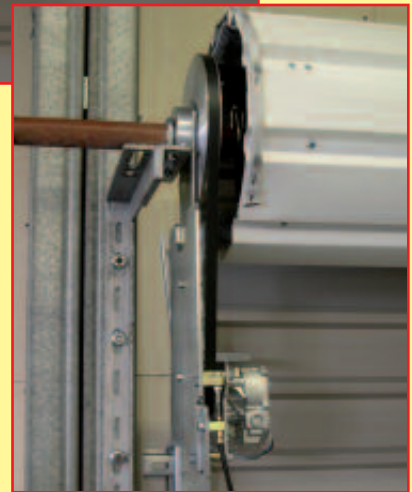

815-SL SLIM-LINE operator to suit applications with limited clearance

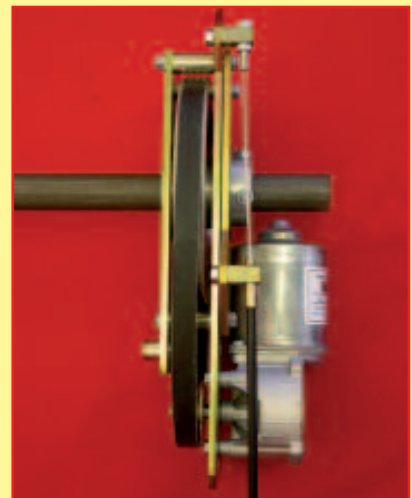

815-SS Live axle operator

- Built in part open programming.
- Shoulder level over-ride lever allowing instant manual operation.
- Safe operation without constant pressure close. Constant pressure close, available with the flip of a switch.
- Pre-wired to accept most photo cells, loop detectors, microwave sensors, treadles, and other accessories.
- Built in light control for dock lights turning light on when door is raised and off when door closes or 4 minute timed control for accessory light. Current consumption: 115v: 3.5amp 6amp with dock light 230v: 2amp 3amp with dock light.
- No thermal overloading.
- Easy service. No limits, limit traveler cams, clutches, or contactors to replace.
- Minimal Parts to Stock reducing inventory.
- Eliminates need for 230V or 460V 3 phase power, further reducing electrical construction costs.
- Safe operation for use of a slide lock for those situations not requiring the use of radio controls.
- Versatile application. Left or right side mount requiring virtually no side room.
- Detects unsafe door operation automatically.

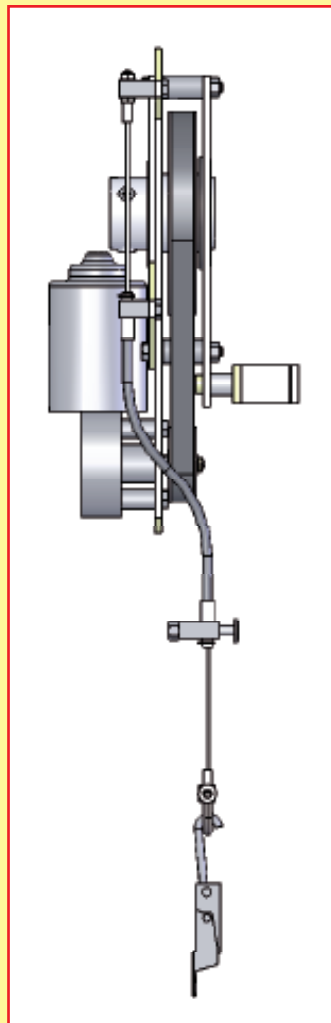

815-SS Live axle operator

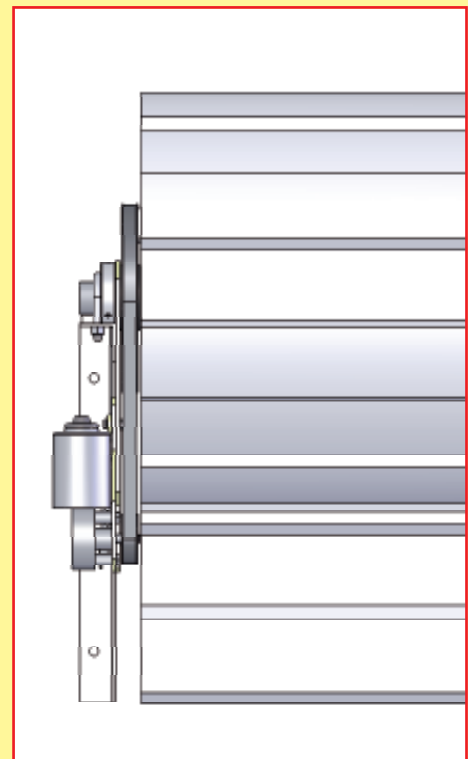

815-SD STANDARD operator

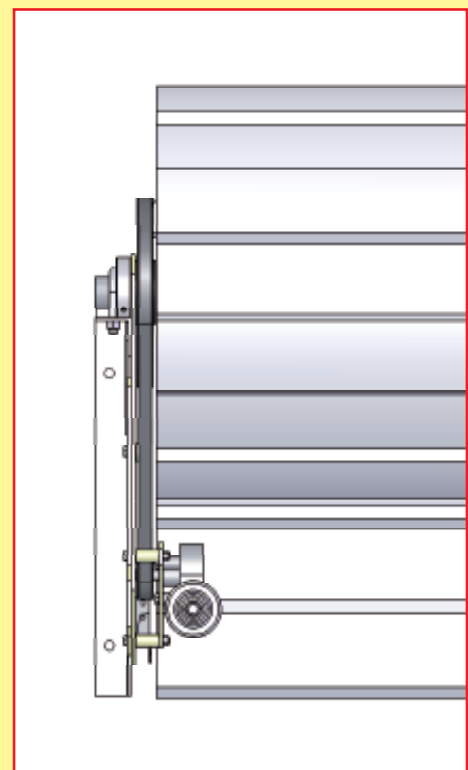

815-SL SLIM-LINE operator to suit applications with limited clearance

WORLDWIDE DISTRIBUTION AVAILABLE • REPRESENTATION IN NORTH AMERICA